

HIRERS FULL NAME (1)

Current Registered Address on Licence

State Postcode

Local Address Where Staying

Postcode A.B.N. No

Licence No. Date of Birth Expiry Date

Phone No.(Home) Mobile Phone No. Work No.

Email Address

STORE ID:.....

Date of Issue

TAX INVOICE NUMBER:

(3) CREDIT CARD DETAILS

NAME EXP DATE

Number

Credit Card Signature X.....

Diners M.C. Visa Amex Debit card (please circle one)

ADDITIONAL DRIVER (2)

Address on Licence

Postcode

Licence No. Date of Birth Expiry Date

Insurance (Please circle one)

over 25 can reduce	under 25 can reduce	All hirers unless reduced
\$1100	\$1500	\$5500
Waiver Fee Applies/Day F/L 5470330	Waiver Fee Applies/Day F/L 5470330	Included STANDARD

Initial

Vehicle Condition Report Agreed by hirer **Initial**

Hirers are responsible for any damage not noted on office copy. Customer is responsible for any traffic infringements, tolls & administration fees & for returning this vehicle in a clean condition

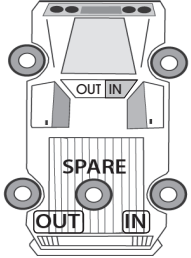

LADDER RACKS OUT YES / NO
 IN YES / NO
 (LADDER RACK REPLACEMENT \$400 EACH)

Jack/Wheel Brace in Place OUT YES/NO IN YES/NO

HIRERS ARE RESPONSIBLE FOR THE ADDITIONAL SINGLE VEHICLE INCIDENT OR IMPOUNDMENT LIABILITY OF \$2000, Initial

(See 3c(ii) & (iii) on page 2 Terms & Conditions of this agreement. This is NOT Waiverable.)

PAYABLE ADDITIONAL ON TOP OF DAMAGE/LOSS LIABILITY EXCESS

FUEL TANK OUT (E 1/4 1/2 3/4 F) **Hirer must refuel & present**

FUEL TANK IN (E 1/4 1/2 3/4 F) **Fuel receipt / Initial...**

FUEL RECEIPT SIGHTED AND CORRECT YES/NO

I certify that the above information is true and correct. I authorise the use of my personal information as detailed in the Privacy TERMS AND CONDITIONS OVERLEAF. I have read and understand the TERMS AND CONDITIONS OVERLEAF and agree to be bound by these conditions.

ADDITIONAL CHARGES ON COMPLETION OF HIRE			
Km's IN	REGO No	TIME IN	Insurance Liability Reduction Waiver
Km's OUT	DATE IN	TIME OUT	Charged Per Day \$
TOTAL Km's	DATE OUT	TOTAL Hours	Windscreen & Tyre Waiver
LESS Free Km's	TOTAL Days	EXTRA DAYS TO BE CHARGED →	Charged Per Day \$
EXCESS Km's	ALL EXCESS KILOMETERS TO BE CHARGED →	Day Rate Hour RateHours @ \$..... \$
	Days @ \$.....	\$
	@ 22c / 39c per Km	\$

CHARGES ON COMMENCEMENT OF HIRE		Area to be used Local / Country	ADDITIONAL DRIVER	Charged Per Day \$
.....HOURS / DAYS / WEEKS @ \$.....	\$	DUE FOR RETURN ON		
Insurance Damage / Loss LIABILITY REDUCTION WAIVER	Charged Per Day \$	Overdue hires charged @ hourly rate unless authorised by place of hire.	CLEANING (\$85) MINIMUM	\$
Windscreen & Tyre Waiver	Charged Per Day \$	COMMENTS:	SUNDRIES / DAMAGE / LOSS LIABILITY	\$
ADDITIONAL DRIVER	Charged Per Day \$		FUEL RECOVERY FEE \$42 Per Quarter Tank	\$
SUB TOTAL INC GST "A"	\$		SUB TOTAL INC GST "C"	\$
TOLL PASS	Charged Per Day \$			\$
SUBT TOTAL	\$		TOTAL inc. GST	\$
DEPOSIT "B"	\$		LESS DEPOSIT "B" taken	\$
TOTAL PAID inc. GST	\$	REFUND RECEIVED SIGNED..... RENTER	AMOUNT DUE / REFUND	\$

Handy Rentals - Terms and Conditions of Hire

1. **Definitions**
- 1.1. "Handy Rentals" shall mean Doverheight Nominees Pty Ltd T/A Handy Rentals, its successors and assigns or any person acting on behalf of and with the authority of Doverheight Nominees Pty Ltd T/A Handy Rentals.
- 1.2. "Hirer" means the person/s or any person acting on behalf of and with the authority of the Hirer requesting Handy Rentals to provide the Vehicle as specified in any proposal, quotation, order, invoice or other documentation, and:
 - (a) if there is more than one Hirer, is a reference to each Hirer jointly and severally; and
 - (b) if the Hirer is a part of a trust, shall be bound in their capacity as a trustee; and
 - (c) includes the Hirer's executors, administrators, successors and permitted assigns.
- 1.3. "Charges" shall mean the cost of the hire of a Vehicle (plus any GST where applicable) as agreed between Handy Rentals and the Hirer subject to clause 3 of this contract.
- 1.4. "Vehicle" shall mean any Vehicle (including all accessories, tools, tyres and equipment and any replacement vehicle) supplied by Handy Rentals to the Hirer. The Vehicle shall be described on the Hire Agreement or any other commencement forms as provided by Handy Rentals to the Hirer.
- 1.5. "Hire" shall mean any or all Hire supplied by Handy Rentals to the Hirer and includes any advice or recommendations.
- 1.6. "Hire Period" shall mean the period commencing on the date as shown in the agreement, and ending on the date the Hirer returns the Vehicle to Handy Rentals.
- 1.7. "GST" means Goods and Services Tax as defined within the "A New Tax System (Goods and Services Tax) Act 1999" (Cth).
2. **Acceptance**
- 2.1. Any instructions received by Handy Rentals and/or its Agents from the Hirer for the supply of Vehicle and/or the Hirer's acceptance of Vehicle supplied by Handy Rentals and/or its Agents shall constitute acceptance of the terms and conditions contained herein.
- 2.2. These terms and conditions may only be amended with the consent of both parties in writing, and shall prevail to the extent of any inconsistency with any other document or contract between the Hirer and Handy Rentals.
- 2.3. Electronic signatures shall be deemed to be accepted by either party providing that the parties have complied with Section 10 of the Electronic Transactions Act 2011 or any other applicable provisions of that Act or any Regulations referred to in that Act.
- 2.4. The Hirer accepts and acknowledges that Handy Rentals must be notified and agree to any extension of the Hire Period in advance of the return date and time or the Hirer shall be deemed to be in breach of this agreement and may forfeit any deposits or additional entitlement and the Vehicle will be immediately reported as stolen and the Hirer shall become liable for any cost outstanding or involved with recovery of the Vehicle.
3. **Errors and Omissions**
- 3.1. The Hirer acknowledges and accepts that Handy Rentals shall, without prejudice, accept no liability in respect of any alleged or actual error(s) and/or omission(s):
 - (a) resulting from an inadvertent mistake made by Handy Rentals in the formation and/or administration of this contract; and/or
 - (b) contained in/omitted from any literature (hard copy and/or electronic) supplied by Handy Rentals in respect of the Services.
- 3.2. In the event such an error and/or omission occurs in accordance with clause 3.1, and is not attributable to the negligence and/or willful misconduct of Handy Rentals; the Hirer shall not be entitled to treat this contract as repudiated nor render it invalid.
4. **Change in Control**
- 4.1. The Hirer shall give Handy Rentals not less than fourteen (14) days prior written notice of any proposed change of ownership of the Hirer and/or any other change in the Hirer's details (including but not limited to, changes in the Hirer's name, address, contact phone or fax numbers, change of trustee or business practice). The Hirer shall be liable for any loss incurred by Handy Rentals as a result of the Hirer's failure to comply with this clause.
5. **Credit Card Information**
- 5.1. Handy Rentals will:
 - (a) keep the Hirer's and/or Credit Card Holders' personal details, including credit card details for only as long as is deemed necessary by Handy Rentals;
 - (b) not disclose the Hirer's and/or Credit Card Holders' credit card details to any third party;
 - (c) not unnecessarily disclose any of the Hirer's and/or Credit Card Holders' personal information, except in accordance with the Privacy Act (clause 22) or where required by law.
- 5.2. The Hirer and/or Credit Card Holders' expressly agree, pursuant to this agreement, liability for:
 - (a) all Hire Charges;
 - (b) all Charges claimed from Handy Rentals in respect of any parking or any other traffic violations during the Hire Period or until such time the Vehicle is returned to Handy Rentals;
 - (c) all loss or damage to the Vehicle (including loss of use), third party damages, legal expenses, assessment fees, towing and recovery, storage and company service charges where:
 - (i) any condition of this agreement and in particular those contained in clause 10, or any other special condition has been breached;
 - (ii) the Vehicle is involved in a single vehicle incident unless Handy Rentals waives such loss to a single vehicle liability amount. A single vehicle incident is defined as any incident where the Vehicle suffers loss or damage as a result of an impact with any or all objects whether animate or inanimate except another vehicle which can be fully identified and all details of the driver provided, or driving in contravention of any legislation or regulation controlling vehicular traffic, including any anti-hooping laws or other illegal purpose;
 - (iii) the Hirer has left the Vehicle unlocked or the keys in the Vehicle;
 - (iv) the Hirer has not kept the key secure and under the personal control of the Hirer;
 - (v) the underbody of the Vehicle is damaged regardless of the cause when no other vehicle is involved;
 - (vi) the Vehicle is totally or partially immersed in water regardless of the cause;
 - (vii) the interior of the Vehicle is damaged regardless of the cause when no other vehicle is involved;
 - (viii) the tyres of the Vehicle are damaged other than due to normal wear;
 - (ix) the Vehicle is damaged by either loading or unloading, other than the normal wear to be expected;
 - (x) the failure to secure properly any load or equipment which leads to loss caused by any part of said load or equipment or any third party vehicle or property;
 - (xi) the Vehicle is damaged by driving it under or into an object lower than the height of the Vehicle;
 - (xii) the Hirer has failed to maintain all fluid levels or failed to contact Handy Rentals when a noted service is due, or failed to immediately rectify or report to Handy Rentals any defect of which the Hirer becomes aware of;
 - (xiii) the Vehicle is impounded by any governing body;
 - (xiv) the Vehicle is not returned in a clean presentable condition (interior and exterior) including, but not limited to cigarette smoke and other odours.
- 5.3. Handy Rentals is entitled to immediately charge the Hirer's nominated credit card for these amounts, and is irrevocably authorised to complete any documentation and take any action to recover from the credit card issuer any and all amounts which may be due by the Hirer pursuant to the terms of this Agreement.
- 5.4. Where the Hirer has instructed Handy Rentals to invoice another party, (including, but not limited to, some other person, corporation, firm or organisation), and such other party fails to make payment when due, the Hirer shall be liable to immediately make payment of the full amount due to Handy Rentals.
6. **Charges and Payment**
- 6.1. At Handy Rentals' sole discretion the Charges shall be either:
 - (a) Handy Rentals' current rate, at the date of delivery of the Vehicle, according to Handy Rentals' current price list; or
 - (b) Handy Rentals' quoted Charges (subject to clause 6.2) which shall be binding upon Handy Rentals provided that the Hirer shall accept in writing Handy Rentals' quotation within thirty (30) days.
- 6.2. Handy Rentals reserves the right to change the Charges:
 - (a) if a variation to the Vehicle which is to be supplied is requested (including a change due to the Hirer's requirements, changes to pick up and drop off points, etc.);
 - (b) as a result of an increase in Handy Rentals' costs due to changes in statutory, government, or local body charges, taxes, levies, etc. with respect to the Vehicle, which are outside the control of Handy Rentals (including, without limitation, increases in the cost of labour or materials, fuel charges or insurance premiums, etc.);
 - (c) upon one (1) month's written notice to the Hirer.
- 6.3. Handy Rentals may charge for Hire by an hourly or kilometre rate (or a combination of both).
- 6.4. At Handy Rentals' sole discretion a non-refundable deposit may be required.
- 6.5. Any sum received by Handy Rentals from or on behalf of the Hirer at or before the commencement of this agreement shall be held by Handy Rentals as security for the return of the Vehicle and as security for payment of any sums owed by the Hirer to Handy Rentals on the termination of this agreement. Upon the termination of the agreement Handy Rentals shall be entitled to apply any sum so held in payment of all amounts owed by the Hirer under the this agreement and any balance shall be refunded to the Hirer.
- 6.6. At Handy Rentals' sole discretion payment shall be:
 - (a) due on delivery of the Vehicle, or
 - (b) the date specified on any invoice or other form as being the date for payment; or
 - (c) failing any notice to the contrary, the date which is seven (7) days following the date of any invoice given to the Hirer by Handy Rentals.
- 6.7. The Hirer acknowledges and accepts that all non-payments shall mean that the Hirer enters into a credit arrangement and shall be required to make payment as per clause 6.6(c) above.
- 6.8. Payment will be made by credit card (a surcharge may apply per transaction), or by any other method as agreed to between the Hirer and Handy Rentals.
- 6.9. The Hirer shall not be entitled to set off against or deduct from the Charges any sums owed or claimed to be owed to the Hirer by Handy Rentals.
- 6.10. Unless otherwise stated the Hire Charges do not include GST. In addition to the Hire Charges, the Hirer must pay to Handy Rentals an amount equal to any GST Handy Rentals must pay for any supply of the Vehicle by Handy Rental under this or any other agreement for the hire of the Vehicle. The Hirer must pay GST, without deduction or set off of any other amounts, at the same time and on the same basis as the Hirer pays the Hire Charges. In addition the Hirer must pay any other taxes and duties (including stamp duties, tolls, fines, penalties, levies, freight, government charges arising out of the Hirer's use of the Vehicle, etc.) that may be applicable in addition to the Hire Charges except where they are expressly included therein.
- 6.11. The Hirer acknowledges and agrees that the Hirer's obligations to Handy Rentals for the supply of the Vehicle shall not cease until:
 - (a) the Hirer has paid Handy Rentals all amounts owing to Handy Rentals; and
 - (b) the Hirer has met all other obligations due by the Hirer to Handy Rentals in respect of all agreements between Handy Rentals and the Hirer.
- 6.12. Receipt by Handy Rentals of any form of payment other than cash shall not be deemed to be payment until that form of payment has been honoured, cleared or recognised, and until then Handy Rentals' rights in relation to the Vehicle, and this agreement, shall continue.
7. **Delivery of Vehicle**
- 7.1. Any time or date given by Handy Rentals to the Hirer is an estimate only. The Hirer must still accept delivery of the Vehicle even if late and Handy Rentals will not be liable for any loss or damage incurred by the Hirer as a result of the delivery being late.
8. **Duration of Hire**
- 8.1. The term of Hire shall be for the period as described overleaf and herein.
- 8.2. When a Vehicle is left at any other place than the premises of Handy Rentals then termination shall be when the Vehicle inspection shall occur at the time of the collection. The Hirer will be responsible for the Vehicle up until this time of termination, inspection, and collection.
- 8.3. Should the Hirer terminate the hire before the stated date and time, the stated rate and term will be amended at the sole discretion of Handy Rentals.
9. **Title**
- 9.1. The Vehicle is, and will at all times remain, the absolute property of Handy Rentals, however the Hirer shall keep Handy Rentals indemnified against all liability in respect of all actions, proceedings, claims, damages, costs and expenses in respect of any injury to persons, or otherwise arising out of the use of the Vehicle during the hire period and whether or not arising from any negligence, failure or omission of the Hirer or any other persons.
- 9.2. The Hirer is not authorised to pledge Handy Rentals' credit for repairs to the Vehicle or to create a lien over the Vehicle in respect of any repairs.
- 9.3. At the expiration of any hire period hereby granted, or as a result of default by the Hirer (including, but not limited to, any default under clause 20 or where the Hirer fails to return the Vehicle to Handy Rentals), the Hirer grants Handy Rentals (or their agent) the right to (as the invitee of the Hirer) enter upon and into land and premises owned, occupied or used by the Hirer, or any premises where the Vehicle is situated and take possession thereof (including any personal property of the Hirer stored therein).
10. **Persons who may drive Vehicle**
- 10.1. The Vehicle may be driven during the Hire Period only by the Hirer and only if:
 - (a) the Hirer or Hirer's employee, representative or agent has been identified as a driver for this Vehicle; and
 - (b) they hold a current Australian, overseas licence written in English, or international driver's licence for a period of not less than two (2) years (and which is an appropriate license for the Vehicle), excluding any time under a learner's permit or a provisional license) at the time when they are driving the Vehicle and where applicable, have the appropriate vehicle endorsement or equivalent in relation to Vehicle Hire (if applicable); and
 - (c) they are over twenty-one (21) years of age and under eighty-five (85) years of age; and
 - (d) they have not given a false name, age, address or driver's licence; and
 - (e) they have not had their driver's license cancelled, endorsed or suspended within the last three (3) years; and
 - (f) at no stage shall they be deemed to be an agent, associate, servant or employee of Handy Rentals for any purpose whatsoever.
- 10.2. If the need arises, consent is given to Handy Rentals to check validity and currency of any drivers licence used in connection with this agreement.
- 10.3. When the Hirer is a Body Corporation, then they shall ensure all drivers have a valid driver's licence and meet the requirements as per clause 10.1 for the term of any Hire.
11. **Hirer's Obligations, Use of the Vehicle and Restrictions**
- 11.1. The Hirer shall, where applicable, ensure that:
 - (a) any applicable seat belt and child restraint laws are complied with;
 - (b) passengers shall only ride in the cab of the Vehicle in designated seats;
 - (c) all the Vehicle's engine oils, coolant and battery levels, and are maintained to the manufacturer's specifications at the Hirer's cost, as set out in the Vehicle's operations manual located in the glove box;
 - (d) the tyres are maintained at their proper pressure;
 - (e) the Vehicle must only be used on a road which is properly formed and constructed as a sealed, metalled or graded gravel road;
- (f) all reasonable care is taken in handling and parking the Vehicle and that it is left securely locked when not in use, with the keys kept under the Hirer's personal control at all times;
- (g) the Vehicle is operated in an appropriate manner that shall during operation the Hirer observes posted speed limits and shall obey all rules and regulations with respect to the correct operation of a motor vehicle;
- (h) any insurance excess payable in relation to a claim made by either the Hirer or Handy Rentals in relation to any damage caused by, or to, the Hire Vehicle whilst the same is hired by the Hirer and irrespective of whether charged by the Hirer's insurers or Handy Rentals'.
- 11.2. The Hirer shall not:
 - (a) drive the Vehicle if Handy Rentals has so directed the Hirer;
 - (b) drive or take the Vehicle into excluded areas as communicated by Handy Rentals;
 - (c) carry any animals in any vehicle without the written permission of Handy Rentals;
 - (d) allow any person(s) to smoke in the Vehicle;
 - (e) operate the Vehicle in any race, pacemaking, reliability trials, contest test, hill climbs, rally, performance or contest, or on any closed road or non-public roadway.
- 11.3. The Hirer shall not:
 - (a) allow the Vehicle to:
 - (i) be used in contravention of any law;
 - (ii) be operated without their authority, and then only by an authorised driver named herein;
 - (iii) be driven by any person if, at the time of them driving the Vehicle, the Hirer or other person is not the holder of current driver's licence appropriate for the Vehicle;
 - (iv) be operated by any driver under the influence of alcohol and/or any drug that affects their ability to drive the Vehicle, or have a blood alcohol content that exceeds the legal limit in the State or Territory in which the Vehicle is driven;
 - (v) propel, push, boost or tow any trailer or load without Handy Rentals' or its agents' written approval and noted on the rental agreement at pickup. (With approval, Hirer shall be permitted to insure and tow one standard 6x4' or 8x5' trailer. Handy Rentals does not provide insurance cover for any trailer towed or goods conveyed therein. Upon request, Hirer shall provide evidence of insurance covering the trailer to be towed);
 - (vi) propel, push, boost or tow any horse float, car trailer, furniture trailer, boat or jet ski;
 - (vii) convey any load which is incorrectly loaded or secured or in contrary to any applicable prevailing road laws or is in excess of that for which the vehicle was manufactured or in contrary to any weight load labels attached to the vehicle or its accessories; in all events this will be limited to a maximum combined towing weight not exceeding 1000kg (one metric ton) GVM;
 - (viii) transport more passengers than may be properly accommodated by the seat belt restraints provided in the Vehicle, or a greater load (weight) than that for which the Vehicle was manufactured;
 - (ix) carry passengers or property for hire or reward of any kind, or carry any flammable substance which has a flash point under 22.8 C, or any other explosive or corrosive materials;
 - (x) be driven in a dangerous manner; or
 - (xi) be used when it is damaged or unsafe.
 - (b) sublet or Hire the Vehicle to any other person.
- 11.4. The Hirer shall be liable for:
 - (a) toll ways, parking or traffic infringement and will supply relevant details as required by the Police and/or Handy Rentals relating to any such parking or traffic infringement and offences, impoundment, towage and storage during the Hire Period. (An administration fee will be charged per Infringement Notice); and
 - (b) unauthorised repairs to the Vehicle;
 - (c) any costs incurred by Handy Rentals where repossession of the Vehicle is taken without prior notice in the event that the Vehicle is illegally parked, used in violation of the law or this agreement, or it is apparently abandoned.
- 11.5. The Hirer acknowledges that they are responsible for the refuelling of the Vehicle prior to its return from Hire. In the event the Vehicle needs to be refuelled upon its return from Hire then the costs of refuelling shall be in addition to the Charges and shall be immediately due and payable by the Hirer.
- 11.6. The Hirer acknowledges and accepts that should the seal or any part of the odometer is broken or has been disconnected, the persons responsible will be reported to the appropriate authority and the Hirer shall be responsible for the extras Charges based on five hundred kilometres (500km) per day at a rate to be specified per kilometre plus any service or repair cost.
- 11.7. The Hirer shall be responsible for all cost of repair to the Vehicle in any of the following circumstances:
 - (a) the Vehicle is driven into any of the restricted areas set out in clause 11.2;
 - (b) the Vehicle is submerged in water;
 - (c) the person driving the Vehicle is proven to be driving under the influence of drugs and/or alcohol;
 - (d) there is damage to the undercarriage or roof due to collision with bridges, tunnels, overhead structures is excluded from the damage cover of the Vehicle;
 - (e) the person driving the Vehicle is:
 - (i) underage;

Handy Rentals - Terms and Conditions of Hire

- (ii) does not have a valid or hold an appropriate class of driver's licence; or
- (iii) unqualified to operate the Vehicle.
- (f) the Vehicle is involved in a theft or conversion.
- 12. Return of the Vehicle**
- 12.1. At Handy Rentals' sole discretion a relocation fee will be applicable to any Vehicle being left at any other agent or business address or any other place other than the address from which the Vehicle was hired and all charges to reposition the Vehicle to its original business address shall be chargeable, plus any Hire period then shorter than originally agreed may have its original Hire rates adjusted according to the actual length of Hire.
- 12.2. The Hirer shall return the Vehicle:
- (a) in the same clean (washed) and tidy condition at the expiry of the term of Hire or a surcharge for cleaning may be imposed upon the Hirer for such cleaning. No refund can be made until a Vehicle has been cleaned and inspected for any damage;
- (b) in good operating condition with the seal on the odometer unbroken and in the same condition (except for normal wear and tear NOT INCLUDING WINDSCREEN AND TYRE DAMAGE) together with all tools, accessories, tyres and equipment);
- (c) fuelled with the correct grade and amount of fuel equal to that at the commencement of the Hire Period. A fuel receipt must be shown and correct on return or any deposit paid may be withheld until correct operation of the Vehicle is confirmed. Should the incorrect grade of fuel be in the Vehicle, any repair cost will be charged to the Hirer and where the fuel level is less than originally supplied in the Vehicle, any shortfall in fuel quantity shall also be charged to the Hirer.
- 12.3. When a Vehicle is left at any other place than the branch location then termination shall be when the Vehicle inspection shall occur at the time of collection. The Hirer will be responsible for the Vehicle up until this time of termination, inspection, and collection.
- 13. Insurance**
- 13.1. The Hirer acknowledges and accepts that Personal Accidental/Medical Insurance is not provided under these terms and conditions and that it is the responsibility of the Hirer to seek independent advice and insurance if so desired.
- 13.2. Subject to the exclusions set out in clause 14, the Hirer (and any driver authorised to drive the Vehicle) is fully indemnified in respect of any liability they might have to Handy Rentals in respect of the loss or damage to the Vehicle and its accessories and spare parts and any consequential loss of revenue or other expenses of Handy Rentals including towing and salvage costs associated with the recovery of the Vehicle and its accessories and spare parts. Subject to the exclusions set out below, the Hirer (and any driver authorised to drive the Vehicle) are indemnified to the extent of \$500,000 in respect of any liability they might have for damage to any property (including injury to any animal) belonging to any other persons and arising out of the use of the Vehicle.
- 13.3. The Hirer acknowledges that it's the Hirer's responsibility to ensure that any personal items carried in or on the vehicle are insured adequately or at all. Handy Rentals shall have no liability to the Hirer whatsoever in respect of such property.
- 13.4. The Hirer acknowledges and accepts that all damage to or loss involving the Vehicle shall be reported to Handy Rentals (and Police or other proper authority where applicable) and a damage/ collision report must be returned to Handy Rentals within twenty-four (24) hours of such notification. Where applicable, the Hirer shall provide Handy Rentals, all paperwork including, but not limited to summons, complaints or other paperwork in relation to any loss that may be a requirement of Handy Rentals' insurer in the event that a claim progresses through the legal system.
- 14. Exclusions**
- 14.1. The indemnities referred to in clause 13 shall not apply where the damage, injury or loss arises when:
- (a) the driver of the Vehicle is under the influence of alcohol or any drug that affects their ability to drive the Vehicle; or
- (b) the Vehicle is in an unsafe or un-roadworthy condition that arose during the course of the Hire and that caused or contributed to the damage or loss, and the Hirer or driver was aware of or ought to have been aware of the unsafe or un-roadworthy condition of the Vehicle; or
- (c) the Vehicle is operated in any race, speed test, rally, or contest, or on any closed road or non-public roadway; or
- (d) the Hirer is not a body corporate or department of State and the Vehicle is driven by any person other than the Hirer and any other person named on the front of this agreement; or
- (e) the Vehicle is driven by any person who at the time when they drove the Vehicle is disqualified from holding or has never held a driver's licence appropriate for that Vehicle; or
- (f) the Vehicle is willfully or recklessly damaged either by the Hirer, or any other person named on the front of this form, or any person driving the Vehicle under the authority of the Hirer; or
- (g) the Vehicle is operated outside the term of the Hire or any agreed extension of that term.
- 15. Rejection of Insurance**
- 15.1. If insurance is rejected, the Hirer acknowledges by signing on the front of this agreement that the Vehicle is hired at the Hirer's sole risk and accepts that they shall be liable to Handy Rentals for any loss of, or damage to, the Vehicle (howsoever arising) plus any consequential loss incurred by Handy Rentals.
- 15.2. If insurance is rejected by the Hirer, the Hirer acknowledges by their signature on the front of this form that they have no insurance cover whatsoever under this agreement in respect of any damage, injury, or loss caused to any person or property.
- 15.3. Where the Hirer nominates their own insurance company for cover then the Hirer shall provide to Handy Rentals proof and currency of policy prior to the commencement of Hire.
- 16. Hirer's Liability**
- 16.1. The Hirer acknowledges that if an insurance claim is declined for any reason that they shall be liable for all damage to, or loss of, the Vehicle plus any consequential loss incurred by Handy Rentals.
- 16.2. Any excess applied (plus GST) shall be for each and every claim. Window glass damage or breakage also carries a separate excess. Such amounts will be collected as part of total amount due under this agreement.
- 17. Handy Rentals' Obligations**
- 17.1. Handy Rentals shall supply the Vehicle in a safe and roadworthy condition with the seal of the odometer unbroken.
- 17.2. Handy Rentals shall be responsible for all ordinary and extraordinary costs of running the Vehicle during the term of the hire except to the extent that by the terms of this agreement those costs are payable by the Hirer.
- 18. Mechanical Repairs and Accidents**
- 18.1. If the Vehicle is damaged, or requires repair or salvage, whether because of any accident or breakdown, the Hirer shall advise Handy Rentals of the full circumstances as soon as practicable.
- 18.2. The Hirer shall not arrange or undertake any repairs or salvage without the authority of Handy Rentals except to the extent that the repairs or salvage are necessary to prevent further damage to the Vehicle or to other property.
- 18.3. The Hirer shall ensure that no person shall interfere with the distance recorder or speedometer or, except in an emergency, any part of the engine, transmission, braking, or suspension systems of the Vehicle.
- 19. The Commonwealth Competition and Consumer Act 2010 and Fair Trading Acts**
- 19.1. Nothing in this agreement is intended to have the effect of contracting out of any applicable provisions of the CCA or the FTA in each of the States and Territories of Australia (including any substitute to those Acts or re-enactment thereof), except to the extent permitted by those Acts where applicable.
- 19.2. Where the Hirer hires the Vehicle as a consumer these terms and conditions shall be subject to any laws or legislation governing the rights of consumers and shall not affect the consumer's statutory rights.
- 19.3. To the maximum extent allowed by law, Handy Rentals gives no express or implied warranty as to any matter whatsoever including, without limitation, the condition of the Vehicle and accessories or its merchantability or fitness for any particular purpose.
- 20. Default and Consequences of Default**
- 20.1. Interest on overdue invoices shall accrue from the date when payment becomes due daily until the date of payment at a rate of 2.5% per calendar month and such interest shall compound monthly at such a rate after as well as before any judgement.
- 20.2. If the Hirer owes Handy Rentals any money the Hirer shall indemnify Handy Rentals from and against all costs and disbursements incurred by Handy Rentals in recovering the debt (including but not limited to internal administration fees, legal costs on a solicitor and own client basis, Handy Rentals' contract default fee, and bank dishonour fees).
- 20.3. Further to any other rights or remedies Handy Rentals may have under this contract, if a Hirer has made payment to Handy Rentals, and the transaction is subsequently reversed, the Hirer shall be liable for the amount of the reversed transaction, in addition to any further costs incurred by Handy Rentals under this clause 20, where it can be proven that such reversal is found to be illegal, fraudulent or in contravention to the Hirer's obligations under this agreement.
- 20.4. Without prejudice to Handy Rentals' other remedies at law Handy Rentals shall be entitled to cancel all or any part of any order of the Hirer which remains unperformed in addition to and without prejudice to any other remedies Handy Rentals may have and all amounts owing to Handy Rentals shall, whether or not due for payment, become immediately payable in the event that:
- (a) any money payable to Handy Rentals becomes overdue, or in Handy Rentals' opinion the Hirer will be unable to meet its payments as they fall due; or
- (b) the Hirer has exceeded any applicable credit limit provided by Handy Rentals;
- (c) the Hirer becomes insolvent, convenes a meeting with its creditors or proposes or enters into an arrangement with creditors, or makes an assignment for the benefit of its creditors; or
- (d) a receiver, manager, liquidator (provisional or otherwise) or similar person is appointed in respect of the Hirer or any asset of the Hirer.
- 21. Cancellation**
- 21.1. Without prejudice to any other remedies Handy Rentals may have, if at any time the Hirer is in breach of any obligation (including those relating to payment) or if the Vehicle is damaged, Handy Rentals may suspend or terminate the supply of Vehicle to the Hirer and any of its other obligations under the terms and conditions. Handy Rentals will not be liable to the Hirer for any loss or damage the Hirer suffers because Handy Rentals has exercised its rights under this clause.
- 21.2. Handy Rentals may cancel these terms and conditions or cancel delivery of the Vehicle at any time before the Vehicle is delivered by giving written notice. Handy Rentals shall not be liable for any loss or damage whatever arising from such cancellation.
- 21.3. In the event that the Hirer cancels delivery of the Vehicle the Hirer shall be liable for any loss incurred by Handy Rentals (including, but not limited to, any loss of profits) up to the time of cancellation or as a direct result of the cancellation.
- 22. Privacy Act 1988**
- 22.1. The Hirer authorises Handy Rentals and its agents to collect and receive their personal information in connection with this hire agreement. All information is collected and used in accordance with the privacy policies of Handy Rentals and its agents. A copy of the Handy Rentals privacy policy is available on our website.
- 22.2. The Hirer agrees for Handy Rentals to obtain from a credit reporting body (CRB) a credit report containing personal credit information (e.g. name, address, D.O.B, occupation, previous credit applications, credit history) about the Hirer in relation to credit provided by Handy Rentals or its agents.
- 22.3. The Hirer agrees that Handy Rentals may exchange information about the Hirer with those credit providers and with related body corporates for the following purposes:
- (a) to assess an application by the Hirer; and/or
- (b) to notify other credit providers of a default by the Hirer; and/or
- (c) to exchange information with other credit providers as to the status of this credit account, where the Hirer is in default with other credit providers; and/or
- (d) to assess the creditworthiness of the Hirer including the Hirer's repayment history in the preceding two (2) years.
- 22.4. The Hirer consents to Handy Rentals being given a consumer credit report to collect overdue payment on commercial credit.
- 22.5. The Hirer agrees that personal credit information provided may be used and retained by Handy Rentals for the following purposes (and for other agreed purposes or required by):
- (a) the provision of Goods; and/or
- (b) analysing, verifying and/or checking the Hirer's credit, payment and/or status in relation to the provision of Goods; and/or
- (c) processing of any payment instructions, direct debit facilities and/or credit facilities requested by the Hirer; and/or
- (d) enabling the collection of amounts outstanding in relation to the Goods.
- 22.6. Handy Rentals may give information about the Hirer to a CRB for the following purposes:
- (a) to obtain a consumer credit report;
- (b) allow the CRB to create or maintain a credit information file about the Hirer including credit history.
- 22.7. The information given to the CRB may include:
- (a) personal information as outlined in 22.1 above;
- (b) name of the credit provider and that Handy Rentals is a current credit provider to the Hirer;
- (c) whether the credit provider is a licensee;
- (d) type of consumer credit;
- (e) details concerning the Hirer's application for credit or commercial credit (e.g. date of commencement/termination of the credit account and the amount requested);
- (f) advice of consumer credit defaults, overdue accounts, loan repayments or outstanding monies which are overdue by more than sixty (60) days and for which written notice for request of payment has been made and debt recovery action commenced or alternatively that the Hirer no longer has any overdue accounts and Handy Rentals has been paid or otherwise discharged and all details surrounding that discharge (e.g. dates of payments);
- (g) information that, in the opinion of Handy Rentals, the Hirer has committed a serious credit infringement;
- (h) advice that the amount of the Hirer's overdue payment is equal to or more than one hundred and fifty dollars (\$150).
- 22.8. The Hirer shall have the right to request (by e-mail) from Handy Rentals:
- (a) a copy of the information about the Hirer retained by Handy Rentals and the right to request that Handy Rentals correct any incorrect information; and
- (b) that Handy Rentals does not disclose any personal information about the Hirer for the purpose of direct marketing.
- 22.9. Handy Rentals will destroy personal information upon the Hirer's request (by e-mail) or if it is no longer required unless it is required in order to fulfil the obligations of this contract or is required to be maintained and/or stored in accordance with the law.
- 22.10. The Hirer can make a privacy complaint by contacting Handy Rentals via e-mail. Handy Rentals will respond to that complaint within seven (7) days of receipt and will take all reasonable steps to make a decision as to the complaint within thirty (30) days of receipt of the complaint. In the event that the Hirer is not satisfied with the resolution provided, the Hirer can make a complaint to the Information Commissioner at www.oaic.gov.au.
- 23. Personal Property Securities Act 2009 ("PPSA")**
- 23.1. In this clause financing statement, financing change statement, security agreement, and security interest has the meaning given to it by the PPSA.
- 23.2. Upon assenting to these terms and conditions in writing the Hirer acknowledges and agrees that these terms and conditions constitute a security agreement for the purposes of the PPSA and creates a security interest in all Vehicles and/or collateral (account) – being a monetary obligation of Handy Rentals to Handy Rentals for Hire – that has previously been supplied and that will be supplied in the future by Handy Rentals to the Hirer.
- 23.3. The Hirer and the Guarantor undertake to:
- (a) promptly sign any further documents and/or provide any further information (such information to be complete, accurate and up-to-date in all respects) which Handy Rentals may reasonably require to:
- (i) register a financing statement or financing change statement in relation to a security interest on the Personal Property Securities Register;
- (ii) register any other document required to be registered by the PPSA; or
- (iii) correct a defect in a statement referred to in clause 23.3(a)(i) or 23.3(a)(ii);
- (b) indemnify, and upon demand reimburse, Handy Rentals for all expenses incurred in registering a financing statement or financing change statement on the Personal Property Securities Register established by the PPSA or releasing any Vehicle charged thereby;
- (c) not register a financing change statement in respect of a security interest without the prior written consent of Handy Rentals;
- (d) not register, or permit to be registered, a financing statement or a financing change statement in relation to the Vehicle in favour of a third party without the prior written consent of Handy Rentals; and
- 23.4. Handy Rentals, the Hirer and the Guarantor agree that sections 96, 115 and 125 of the PPSA do not apply to the security agreement created by these terms and conditions.
- 23.5. The Hirer and the Guarantor waive their rights to receive notices under sections 95, 118, 121(4), 130, 132(3)(d) and 132(4) of the PPSA.
- 23.6. The Hirer and the Guarantor waive their rights as a grantor and/or a debtor under sections 142 and 143 of the PPSA.
- 23.7. Unless otherwise agreed to in writing by Handy Rentals, the Hirer and the Guarantor waive their right to receive a verification statement in accordance with section 157 of the PPSA.
- 23.8. The Hirer and the Guarantor must unconditionally ratify any actions taken by Handy Rentals under clauses 23.2 to 23.5.
- 23.9. Subject to any express provisions to the contrary nothing in these terms and conditions is intended to have the effect of contracting out of any of the provisions the PPSA.
- 23.10. Only to the extent that the hire of the Vehicle exceeds a two (2) year hire period with the right of renewal shall clause 23 apply as a security agreement in the form of a PPS Lease in respect of Section 20 of the PPSA, in all other matters this clause 23 will apply generally for the purposes of the PPSA.
- 24. General**
- 24.1. The failure by either party to enforce any provision of these terms and conditions shall not be treated as a waiver of that provision, nor shall it affect that party's right to subsequently enforce that provision. If any provision of these terms and conditions shall be invalid, void, illegal or unenforceable the validity, existence, legality and enforceability of the remaining provisions shall not be affected, prejudiced or impaired.
- 24.2. These terms and conditions and any contract to which they apply shall be governed by the laws of Western Australia, the state in which Handy Rentals has its principal place of business, and are subject to the jurisdiction of the Perth Courts in Western Australia.
- 24.3. Subject to clause 19, Handy Rentals shall be under no liability whatsoever to the Hirer for any indirect and/or consequential loss and/or expense (including loss of profit) suffered by the Hirer arising out of a breach by Handy Rentals of these terms and conditions (alternatively Handy Rentals' liability shall be limited to damages which under no circumstances shall exceed the Price of the Goods).
- 24.4. Handy Rentals may licence and/or assign all or any part of its rights and/or obligations under this contract without the Hirer's consent.
- 24.5. The Hirer cannot licence or assign without the written approval of Handy Rentals.
- 24.6. Handy Rentals may elect to subcontract out any part of the Services but shall not be relieved from any liability or obligation under this contract by so doing. Furthermore, the Hirer agrees and understands that they have no authority to give any instruction to any of Handy Rentals' sub-contractors without the authority of Handy Rentals.
- 24.7. The Hirer agrees that Handy Rentals may amend these terms and conditions by notifying the Hirer in writing. These changes shall be deemed to take effect from the date on which the Hirer accepts such changes, or otherwise at such time as the Hirer makes a further request for Handy Rentals to provide a Vehicle on hire to the Hirer.
- 24.8. Neither party shall be liable for any default due to any act of God, war, terrorism, strike, lock-out, industrial action, fire, flood, storm or other event beyond the reasonable control of either party.
- 24.9. Both parties warrant that they have the power to enter into this contract and have obtained all necessary authorisations to allow them to do so, they are not insolvent and that this contract creates binding and valid legal obligations on them.

This guideline:

- provides practical advice for loading and restraining loads on utes; and
- cannot cover all situations, so you are responsible for ensuring the method used are appropriate for the load being transported.

All damage to vehicles, loads, people property etc is the responsibility of the hirer and they are to pay for damages. If staff assist, the responsibility still remains on the hirer to check.

Load Limits

The following limits apply to the vehicle rented:

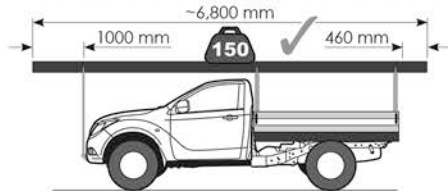

Maximum evenly spread load and overhangs



Reduce weight when inclined load. Recommended max overhang 10% of length.

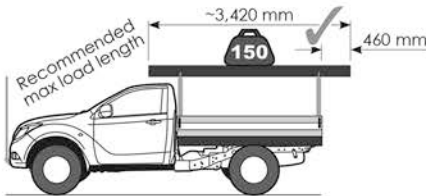

Max 450 mm rear overhang.
Max 150 kg for evenly spread load.



Driver's vision must not be obstructed. Flexible material may not be suitable on racks.

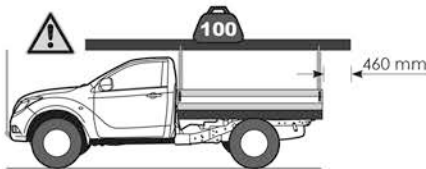

Avoid unequal overhangs as this may overload the front support and/or flex over the cab.

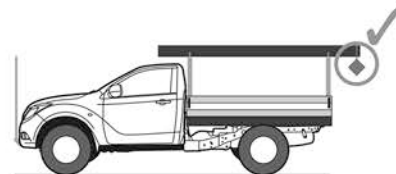

Use a bright coloured flag at least 300 mm square during the day and a red light at night for rear overhanging loads.

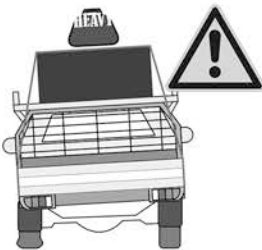

Vehicle performance is affected by tall/heavy loads on racks, especially sideways.

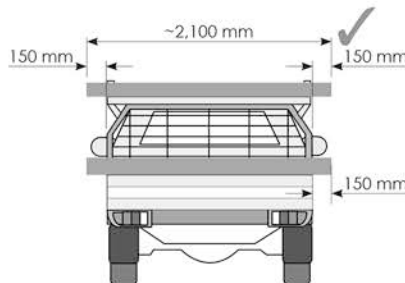

Maximum side overhang 150 mm

Load Restraint Requirements

- ✓ Where possible, load within the cargo area only.
- ✓ All items longer than 1 metre to have minimum 2 lashings.
- ✓ Wrap the restraint around the load (belly wrap) where possible.
- ✓ All items loaded on an incline must be tied down.
- ✗ No slippery/low friction surfaces (eg metal to metal). Items must be placed on surfaces such as timber or rubber.

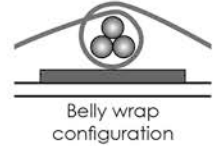

All items not restrained by a restraint must:

- ✓ Have a cargo net or cover over of sufficient strength that will prevent any object escaping (will not fit through any holes);
- ✓ Be blocked in a way that will not allow the load to pierce the sides/front;
- ✗ Not be prone to movement; and
- ✗ Be contained so that the bottom of the item/pack is at least 200 mm from the top of the sides.

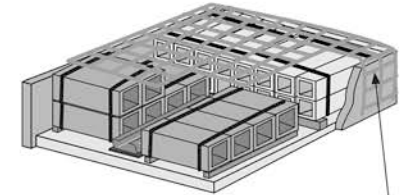

Loose items must be under cargo nets and must not extend more than 100 mm above the sides. Tie down larger items with restraints.

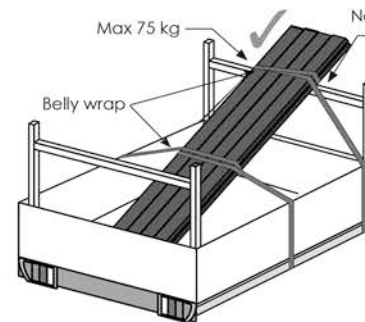

Belly wrap all multi-abreast product or bundles

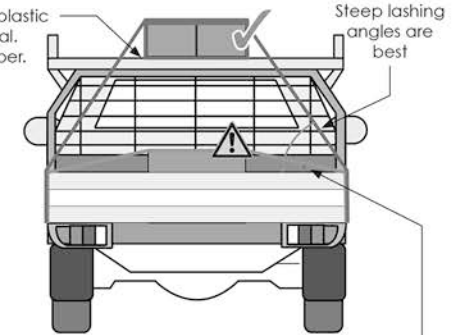

If low lashing angle, then consider blocking, use of belly wrap, and/or removing drop-gate

Weight Limits per Restraint

Restraint angle	35mm ratchet tightened webbing	25mm ratchet tightened webbing	25mm hand tightened webbing	Rope with single hitch (truck knot)
30° - 60°	250 kg	100 kg	35 kg	50 kg
60° - 90°	430 kg	170 kg	60 kg	85 kg

Note: Do not exceed "ladder rack capacity (75 kg for each of the main two racks = 150 kg total).

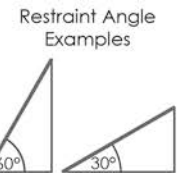

This document is provided for guidance only. Engistics has developed this guideline to comply with the relevant standards and legislation, however it remains the responsibility of the user to ensure that the methods used are adequate for a particular situation. Additional requirements may be necessary under some conditions. Engistics makes no warranty as to the use of this guideline in all circumstances. The information contained in this guideline is confidential and remains the property of Handy Rentals and Engistics. Any changes to this guideline must be approved by Engistics.